



STAYING SHARP

manager's desk

By Keith Jennings

# Clean shop, new attitude

**A**pril's here and your shop may bear the scars of a busy first quarter, with immense clutter in its wake. This isn't necessarily a bad thing, but with warmer weather knocking at your shop bay doors, it's a good time to schedule a day for reorganizing and whipping the place into shape.

I've heard various opinions as to whether a clean shop really has much impact on an operation. You've probably seen the extremes. Some places are so clean you wish your house was as well organized, while others are so cluttered and dirty it's a wonder anything is accomplished.

Whatever the condition of your shop, now is a great time to clean it before the hot months of summer arrive. I lean towards maintaining a clean and tidy shop, but this wasn't always the case. During my first few years in business, shop cleanliness seemed unimportant. After all, it's a shop! Aren't things supposed to be greasy?

After relocating to a new facility in 1996 that we owned instead of leased, I adopted a different attitude. Of course, we spent a few weeks arranging things and debating where the CNC lathe and scrap bins should go. Eventually, we found ourselves putting a lot of thought into the precise layout of many things that we didn't previously care about.

Keeping a clean shop was really embedded in our minds after a trip to Europe that included shop tours. Shops there practiced "clean and tidy" down to the tiniest details, and this mind-set was embedded in their workers' routines, increasing efficiency. The details included small things like perfectly placed tools and machine manuals to minimize time spent looking for them, and bigger things like impeccably maintained machines to minimize downtime and ensure automated operation. All seemingly common functions, but practiced to an extreme.

After meeting some owners and managers, it became clear that stricter employment laws required

it. Companies operating within such constraints must be even more efficient to maintain a reasonable level of profit. They must take advantage of every option and are innovative as a result. Many of these ideas and techniques are effective for U.S. shops just the same. Not so much the mandatory 40-hour pay to employees who might have only worked 35 hours, the beer drinking during lunch breaks or the smoking throughout the production area, but the benefits of a clean and efficient shop space were obvious.

Does all of this mean us Yanks should adopt a Euro-modeled manufacturing facility? No. Thankfully, some things are different in the U.S. But scheduling a companywide cleanup day or week may be the attitude adjustment a shop needs. Even for those who maintain a well-organized place, there's likely a back corner, a parts rack or an outside area that's accumulated an undocumented pile of stuff.

*Scheduling a companywide cleanup day or week may be the attitude adjustment a shop needs.*

If your reorganizing budget is limited, even things like the removal of unnecessary clutter, machine maintenance and cleaning, remodeling of a work space or brushing away the cobwebs offers a noticeable impact. If you're able to budget funds for things like racks, carts, storage cabinets and floor treatment, the improvement will be dramatic—and safer for workers.

Getting employees involved in a companywide project is the way to go because it instills an attitude of ownership and involvement. It's their work space after all, and they deserve a professionally maintained and safe work environment that encourages quality. A well-maintained shop doesn't guarantee a wonderfully efficient and happy workforce, but adopting this mentality throughout your company will establish credibility among employees and customers alike. **CTE**

**About the Author:** Keith Jennings is president of Crow Corp., Tomball, Texas, a family-owned company focusing on machining, laser cutting, metal fabrication and metal stamping. He can be e-mailed at [kjennings@jwr.com](mailto:kjennings@jwr.com).

# Heat treating

By Dr. Laroux K. Gillespie

Heat treating a part can change its metal properties in several ways. Heat treating can harden, toughen and soften. It can help diffuse chemicals in the metal so the part's properties are more uniform throughout, and it can reduce damaging residual stresses to extend part life. All of those changes are possible by controlling the way a metal is heated.

For any specific material, the results of heat treating depend upon the temperature and the amount of time the material is held at that temperature. The cooling rate for a specific metal, such as steel, determines its microstructure and properties. It is also possible to change the properties by adding chemicals to the surface while the material is hot or being cooled. Casehardening, for example, packs carbon material around the part and heats the part to a temperature that causes the carbon to enter the metal's surface. Higher carbon content allows a steel to become harder.

Isothermal transformation is the key to understanding what the material properties will be after cooling. For example, if the material is cooled at 1,000° F/sec. until it is below 200° F, a martensite structure is produced, which is magnetic and hard. At a slower cooling rate, such as 60° F/sec., some pearlite, which is relatively soft, will develop, but some of the material will have a martensite structure. If cooled at a rate of 1° to 30° F/sec. or slower, almost all of the

Tempering's effect on the mechanical properties of AISI 1040 steel.

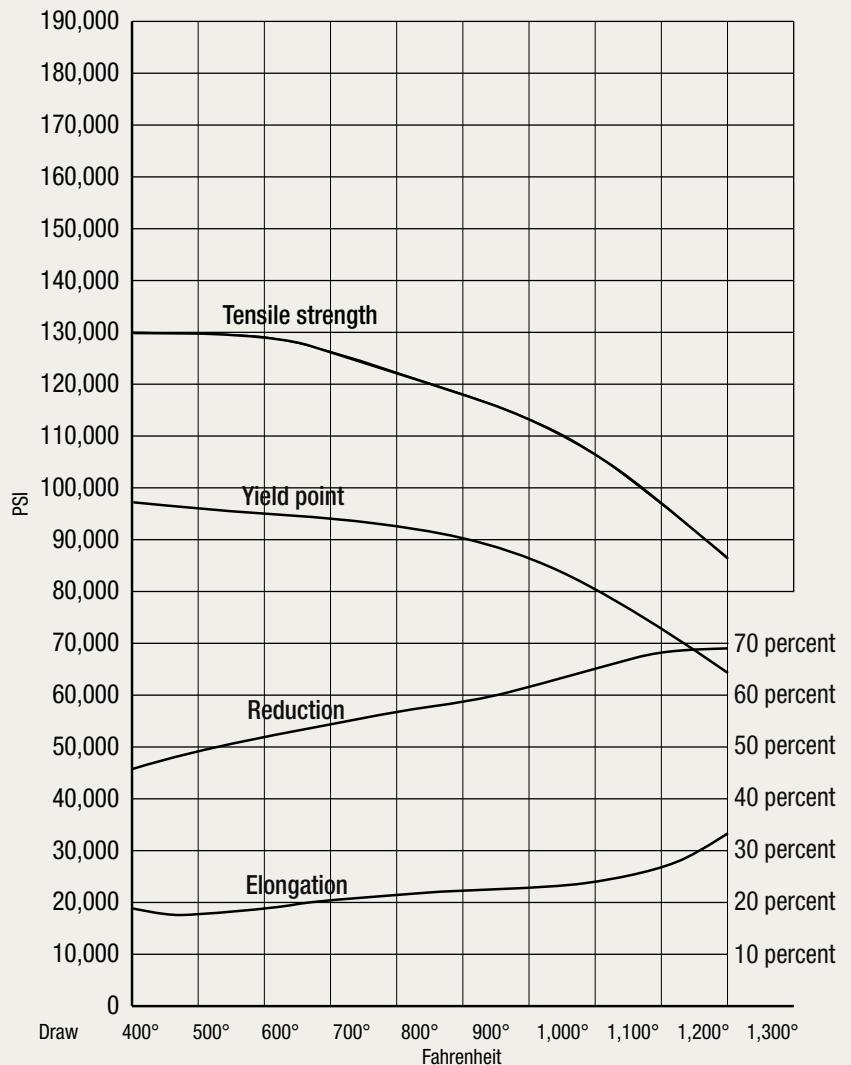

Normalized at 1,650° F, reheated to 1,550° F, quenched in water.



*fast*  
**forward**

Don't miss the  
**MAY ISSUE** of  
CUTTING TOOL ENGINEERING!

- Making Medical Parts
- Boring
- Laser Machining
- Rapid Prototyping

material will be pearlite.

Steel is in an austenite ( $\gamma$ ) phase when heated to 1,333° F. Austenite is a soft material. If quenched rapidly, the steel stays in that phase until it reaches about 400° F and then starts turning into martensite. Once the temperature falls to about 200° F, the transformation to martensite is completed.

Martensite's hardness is 53 to 67 HRC, and pearlite is about 15 HRC. Bainite is up to 34 HRC but is less ductile than pearlite. Because tensile strength is almost directly proportional to hardness, a faster cooling rate produces stronger steels—ones that have transformations similar to AISI 1080.

By raising the temperature and holding it at just below 400° F for 1 to 2 hours, the steel becomes "tempered," attaining a more uniform phase throughout the material. Higher temperatures are also used to temper some of the retained austenite to bainite and cementite, or iron carbide. But for tempering temperatures above 400° F, the steel starts to soften. The higher the temperature, the softer the steel will be. In contrast to making a more uniform and less brittle steel, annealing softens steel. To provide a soft pearlitic structure, 1040 steel, for example, is annealed at 1,450 to 1,600° F for 1 hour and then cooled to 1,200° F.

Dropping the material into water results in a quench rate of about 300° F/sec. In contrast, the quench rate in oil is 30° F/sec. and in air is 1° F/sec.

Tempering the martensitic steel reduces its hardness and tensile strength. As the figure shows, heating AISI 1040 martensitic steel to 1,200° F and holding it there reduces its tensile strength from 130,000 to less than 100,000 psi, but the material is more ductile with 28 percent elongation rather than 20 percent.

The cooling rate is important, but when a steel bar is quenched, only its outer surface experiences the fast cooling rate. Below the surface, the rate is much slower, resulting in softer steel and martensite not being the only phase. For example, at the surface when a 2"-dia. bar is cooled—end quenched—in still water at 490° F/sec., the bar's center

at ½" from the end is experiencing a cooling rate of 32° F/sec. At 1" from the end, the rate is 8° F/sec.

Then, a bar of 1080 steel would develop a lot of pearlite in its center under these conditions while the exterior would primarily be martensite. These different cooling rates can cause significant residual stresses that warp parts or

lower their fatigue life.

CTE

**About the Author:** LaRoux K. Gillespie, Ph.D., is a retired manufacturing engineer and quality-assurance manager. He is the author of 10 books on deburring and over 200 technical reports and articles on precision machining. He can be e-mailed at [laroux1@myvine.com](mailto:laroux1@myvine.com).



www.**THINBIT**.com

**CUSTOM TOOLING**

**DESIGN-A-GROOVE®**

You need it.  
We design it.  
We make it.  
You've got it.  
It's as simple as that.

KAISER TOOL COMPANY, INC. 888-THINBIT • 888-THINFAX  
For more information go to [www.thinbit.com/dgc](http://www.thinbit.com/dgc)

72

# Brave new world for machine tools?

By George Weimer

Automation is the holy grail of manufacturing. In terms of machining, much has been accomplished. One CNC machine today, for example, is as produc-

tive as a whole shop was 30 years ago, producing higher quality parts with far less labor. So what's next? Is this the final plateau in automation? Not at all, according to industry experts.

The next plateau, however, is not just

more functionality or increased speeds and feeds, although that's coming too. The next big automation boost involves interconnectability and interoperability. What's that? It's computerese for machinery that shares data and perhaps decision making with other machinery through a standard "protocol." It ties the "islands of automation" together.

Those who have been in the industry more than 20 years probably recall something similar being sponsored by General Motors Corp. around 1988. It was called MAP (manufacturing automation protocol). It, too, was going to tie all the operations on a plant floor together via computers. CIM (computer integrated manufacturing) is a similar concept.

Those efforts were largely abandoned. But, another attempt is being made, and it holds great promise because of the Internet. A common protocol for interoperability is being proposed by AMT—The Association For Manufacturing Technology. It's called MTConnect. Can it deliver?

"We worked with University of California, Georgia Tech, CAMX and Sun Microsystems to develop this protocol, which we will demonstrate at IMTS 2008 at the Emerging Technologies Center," Paul Warndorf, AMT vice president of technology, told *Cutting Tool Engineering*. "Some companies will have MTConnect in their booths as well."

The protocol offers a common dictionary and uses the Internet, which is the key difference today when comparing previous attempts to bring more communication automation to manufacturing. What's required for success, which I believe would be spectacular, is for the entire manufacturing equipment and end user world to buy into the concept. Judging from the sponsors already signed up on the MTConnect.org Web site, the concept is creating quite a following already.

Meanwhile one of the world's leading machine tool companies, Haas Automation Inc., Oxnard, Calif., has developed



THE NEW VALUE FRONTIER

## Kyocera...Advancing Productivity

High quality and innovative MILLING solutions guaranteed to improve your productivity...now that's value!

### MSR

Heavy Roughing Cutter



- Double the metal removal rate
- Heavy machining with low cutting force

### MECH

Helical End Mill



NEW!

- Improved chip evacuation
- Maximum machining efficiency

### MEC

Ultra Hurricane Endmills & Facemills



- Low cutting forces and high feed rates
- Excellent shoulder wall surface finish

### MECX

Ultra Hurricane Fine-Pitch Endmills & Facemills



- Low cutting forces
- Ideal for lower horsepower machines

KYOCERA Industrial Ceramics Corporation  
Cutting Tool Division  
130 Industrial Park Rd. Mt. Home, NC 28750  
ph. 800-823-7294 ■ www.kyocera.com ■ ceratip@kyocera.com

THE NEW VALUE FRONTIER



another system called M-Net, which is "compatible with MTConnect but adds to it," said Kurt Zierhut, Haas' director of electrical engineering. "The challenge is to connect all these machines and robots on the shop floor. MTConnect goes a long way towards developing a good dictionary. M-Net, however, solves the discovery and communication problem."

"Discovery" means knowing where the CNC machine is on the Web. M-Net also supplies a bidirectional communication path. That is, it can get data from the machine, including the CNC program, and send data to the machine.

"The next step would be towards command and control in the system. That would require working with OSHA and others in terms of safety and other issues," Zierhut said.

"We are developing MTConnect free of charge," said John B. Byrd III, president of AMT. "The protocol is open to all and is what will make the 21st century so very different in terms of manufacturing."

M-Net is also free and open. "Haas welcomes other players in the machining, welding and material-handling industries," said Zierhut. The AMT and Haas systems are the next plateau in the march towards more sophisticated automation.

Seems the Internet's amazing potential has been noticed and exploited by the machine tool industry. Both M-Net and MTConnect are complementary and offer great expectations for manufacturing—if the rest of industry can agree to the new standards. CTE

**About the Author:**

George Weimer, a freelance writer based in Lakewood, Ohio, has an extensive back in the metalworking industry's business press. Contact him by e-mail at [gweimer@jwr.com](mailto:gweimer@jwr.com).



# Rough Around the Edges?



## Front and Back Hole Deburring In a Single Pass

• Z-Burr too a bit save you time and money. Our patented system allows you to easily change the speed and adjust the cutting pressure quickly while the tool is still in the machining. Plus, our durable bits are available in a wide variety of sizes, deburring holes from .010" to 2.0". Easy. Fast. Built to Last.

[www.ezburr.com](http://www.ezburr.com) 800.793.2877 Plymouth, MI



### KEO Cutters is focused on Special Cutting tools. KEO KWIK Shipment Program represents our commitment.

- Tool styles included are: Plain Style Center Drills in HSS or Cobalt with 60°, 82° or 90°, RH or LH Cut, Single End or Double End. Also Spotting & Centering Drills and NC Spotting Drills. Available points include Conventional, Split Point and Facet Points.
- Body Diameters include 3/16", 1/4", 3/8", 1/2", 5/8", 3/4" and 1" up to 10" overall length +1/16" minus 1/16". Metric sizes available in HSS only include 4mm, 5mm, 6.3mm and 10mm.
- Tell KEO you heard about KEO KWIK in Cutting Tool Engineering magazine.

KEO KWIK Shipment tools will be shipped to an authorized KEO distributor in two weeks. Call your local distributor for a KWIK quote.



KEO Cutters  
28040 Easy Street  
Warren, MI  
48099-4100

P: 588-771-2050  
F: 588-771-2052  
[www.keocutters.com](http://www.keocutters.com)

# Basic hand tools

By Frank Marlow, P.E.

Having just the right tool for a job makes all the difference in getting the job done quickly and correctly. Presented here are six categories of basic

machine shop hand tools and how they are used. For every category of tool, there are dozens of variations in size, shape and design.

■ **Gunsmiths' screwdriver sets consist of 20 screwdrivers held in a stand.**

Sets are also available in kits with two handles and several dozen different interchangeable blades. A typical set has screwdrivers in three to six blade thicknesses in each of nine standard blade widths. For example, a screwdriver with a 0.360"-wide blade has six blade thicknesses: 0.020", 0.025", 0.030", 0.035", 0.040" and 0.050". This ensures that a screwdriver with the proper blade width and slot thickness is available for most screw heads. The screwdriver bits, or tips, fit into the screwdriver handles and are held in place by magnets. Most kits contain standard, Phillips, Torx, square and hex bits.

■ **An automatic center punch automatically strikes a blow on its punch-like tip when downward pressure is applied to its cap.** No hammer is needed. An automatic center punch's one-handed operation allows a machinist to see the scribe marks, which is impossible when holding both a hammer and a punch. Turning the adjustable knurled cap regulates the blow's force. Automatic center punches are typically about 5" long and have screw-on replaceable tips.

■ **Bench blocks are miniature anvils made of hardened and ground steel.** They range from 1¼" to 5" in diameter and are used as a work support surface when filing, drilling and driving out pins. Work placed on them does not pick up surface marks because of the blocks' smooth top surface. Some designs have V-grooves for holding round work, while others have holes, slots or slits. Some designs are hexagonal to permit mounting in a vise. Bench blocks are for fine work—not heavy hammering—and are useful for working on instruments, clocks, watches and firearms.

■ **The basic styles of clamps are the C-clamp and the machinists' clamp.** The C-clamp is applied with its single screw. The machinists' clamp is applied by snugging up the jaws so they are parallel using the center clamp screw and then pinching the jaws together

**FINISHING SOLUTIONS FOR A LEAN WORLD**

**IS YOUR FINISHING OPERATION A TOOL CHANGE OR A DEPARTMENT?**

**ATB™ DISC BRUSHES**

**OSBORN**  
FINE FINISHING  
Austrian Made

(800) 720-3358 www.osborn.com

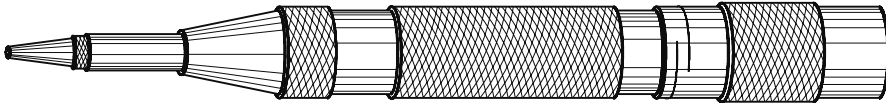

All images: P.J. Tallman

An automatic center punch can be operated with one hand by a machinist.

by tightening the other clamp screw. Both types are available in various sizes. They are essential when holding a metal pattern against a workpiece or drilling two pieces of stock simultaneously. Brass, plastic or cardboard are sometimes placed between the clamp's faces and the workpiece to prevent workpiece marring.

■ **Because of their ratchet-locking mechanism, hemostats can pick up and hold parts firmly with little effort.** Machinists sometimes use them to pick up hot or cold objects or to dip or swab an object while keeping their fingers dry. Hemostats handle objects too small for pliers and too big for tweezers. They are made of stainless steel. Some

hemostats have ends with mating teeth that work well for gripping cloth, rubber, vinyl and other soft materials. He-

mostats can be converted into miniature tongs by grinding away their ratchet mechanisms.

■ **Various types of pliers are common in a machine shop.** Tongue-and-groove pliers are the most popular design. They have dislodged the traditional slip-joint pliers from the leading position because of two advantages:

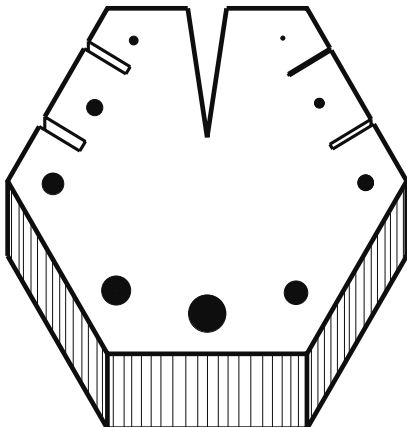
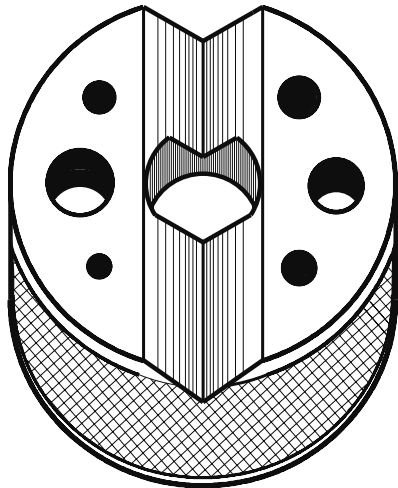

Two examples of bench block designs.

# TAW-TPW MILLING OPTIMIZED



*Increased Productivity with High Feed Insert Option*  
*Increased Accuracy with improved axial and radial run-out*  
*Reduced Cutting Forces with high edge inclination inserts*  
*Reduced body weight without reducing toughness*

**At Tungaloy It's All About Output**

**WHAT ARE YOU USING?**

Ask your Tungaloy representative  
 about our current FREE cutter promotion.



**Tungaloy America, Inc.**  
 1229 A Michael Drive, Wood Dale, IL 60191  
 Phone: 888.854.2204 • Fax: 888.854.0202  
[www.tungaloyamerica.com](http://www.tungaloyamerica.com)

the tongue-and-groove design is quite strong so once its jaw distance is set, it will not change; and the jaws are set at an angle to the handles and are more comfortable for many jobs.

Slip-joint pliers are a classic design and remain popular.

Needle-nose pliers can access tight spots and make sharp bends and loops

in wire. Although usually used in electrical and electronics work, needle-nose pliers are ideal for bending and adjusting springs and sheet metal parts. They are available in several lengths and needle tapers.

Diagonal cutters snip copper, brass, iron and steel wire but will be damaged if used to cut piano wire. Diagonal cut-

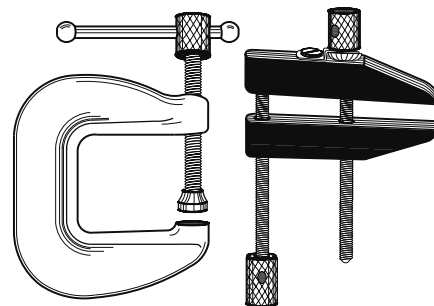

The C-clamp (left) and machinists' clamp are the two basic styles of clamps.

ters are also available in small sizes for electronics work.

Multipurpose pliers were originally designed for crimping AMP-brand solderless electrical connectors. But they have become popular in their own right because they can also strip insulation from wire, trim five common sizes of brass screws to length without destroying their threads, cut wire and crimp smaller clamps for steel and stainless steel cable.

Vise-grip pliers are great for holding small parts for drilling, grinding, wire brushing and sanding. They hold pipe, rounds and square stock and are useful in clamping one part to another for welding, soldering, drilling or patterning. They can even remove some "one-way" screws by clamping onto their edges. Their disadvantage is their jaws leave marks on the work.

On the other hand, soft-jaw pliers can safely be used on easily marked or scratched workpieces, but cannot exert a lot of torque before their nylon or rubber pads are damaged. CTE

#### About the Author:

Frank Marlow, P.E., has a background in electronic circuit design, industrial power supplies and electrical safety and has worked for Avco Missile Systems,



Boeing, Raytheon, DuPont and Emerson Electric. He can be e-mailed at [orders@MetalArtsPress.com](mailto:orders@MetalArtsPress.com). Marlow's column is adapted from information in his book, "Machine Shop Essentials: Questions and Answers," published by the Metal Arts Press, Huntington Beach, Calif.



### WHAT'S SO SPECIAL ABOUT COLE ENGINEERED PRODUCTS?

#### EVERYTHING!

Cole goes beyond routine to deliver the best overall value for diverse cutting and wear part designs — or any material application requiring tungsten carbide or ceramics.

Unique in our commitment to total process support, engineers team up with customers to optimize the right solution in every application. From raw material selection to final product, Cole Engineered Products are designed to exacting specifications.

- Diverse grades of Tungsten Carbide
- Standard or special coatings
- Ceramics or Cermets
- Ultra-high tolerances

Call for a quote or sales representative and be a part of all that is special with Cole Engineered Products.



Visit us at the 2008 IMTS Show, Booth P2701



COLE ENGINEERED PRODUCTS, INC.

24205 Open Road • Warren, MI 48090 U.S.A.

Tel: (586) 757-8700 • Fax: (586) 757-8900

Email: [info@coleproducts.com](mailto:info@coleproducts.com)

[www.coleproducts.com](http://www.coleproducts.com)

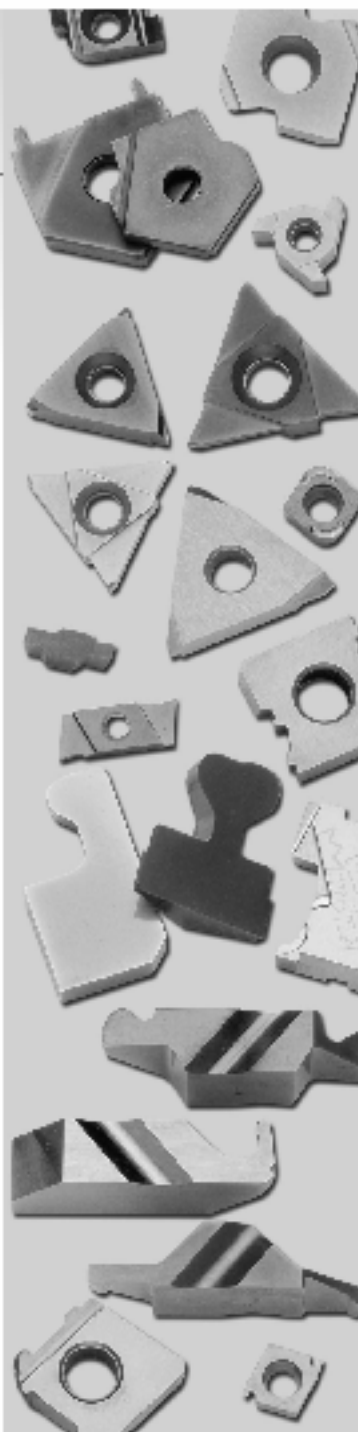

# In Brickyard's backyard

By Bill Kennedy,  
Contributing Editor

Rayco Machine & Engineering Group Inc. will have more than simply sporting interest in the Indianapolis

500, which takes place 3 miles south of the shop's facility. Rayco primarily makes automotive and aerospace components, including ones for the Indy Racing League.

One racecar part that provides ma-

chining challenges is an approximately 8"-long, 1"-dia. titanium suspension component called an antiroll bar blade. A thin, tapering cross section enables the part to be stiff under pressure from one direction and more flexible under pressure in another. As a result, the blade provides varying amounts of flexibility as it rotates, enabling a driver to adjust the car's roll resistance via a cable-linked control in the cockpit.

Rayco begins by cutting a 1½"-dia. Ti6Al4V bar stock into 8" lengths. The shop works with DXF drawings or solid models provided by the race teams or racecar manufacturer Dallara Automobili, Parma, Italy, and programs the parts in Mastercam.

Next, the stock is chucked against a positive stop in a 16C collet on a Hardinge Talent 6/45-SV CNC lathe, with about 2½" exposed for machining.

The first operation is facing the part's end and rough turning OD profile details with a Sumitomo coated, carbide VNMG 332 insert run at 120 sfm and a 0.008-ipr feed. Profile features include a 1½"-dia., 0.080"-wide shoulder and a 1.18"-dia., ½"-wide flat.

After a hole location is marked with a ¼"-dia. HSS spot drill, a 0.687"-dia. cobalt-HSS jobber drill run at 600 rpm and 0.002 ipr drills the part axially to a depth of 0.190". Rayco then puts a ½"×45° chamfer on the hole's mouth and skim cuts the ID to a 0.700" diameter with a boring bar. "Especially for racing, we do that," said Greg Cox, Rayco president, "because you don't want sharp corners on anything that is going to have load on it. You don't want tool lines or tool marks because that is the first place for fractures to start."

Cox noted that racing and flying requirements are similar. "We always say Indy cars are basically just inverted airplanes," he said. "The racers want them to stick to the ground, and aerospace wants them to take off."

After the axial hole is completed, the OD details of the part's end are finished with the VNMG insert run at 150 sfm and 0.004 ipr. Then a Kennametal KC730 NG 2031 RK grooving

## BALINIT® PVD Coatings long live your cutting tools

LONG LIFE

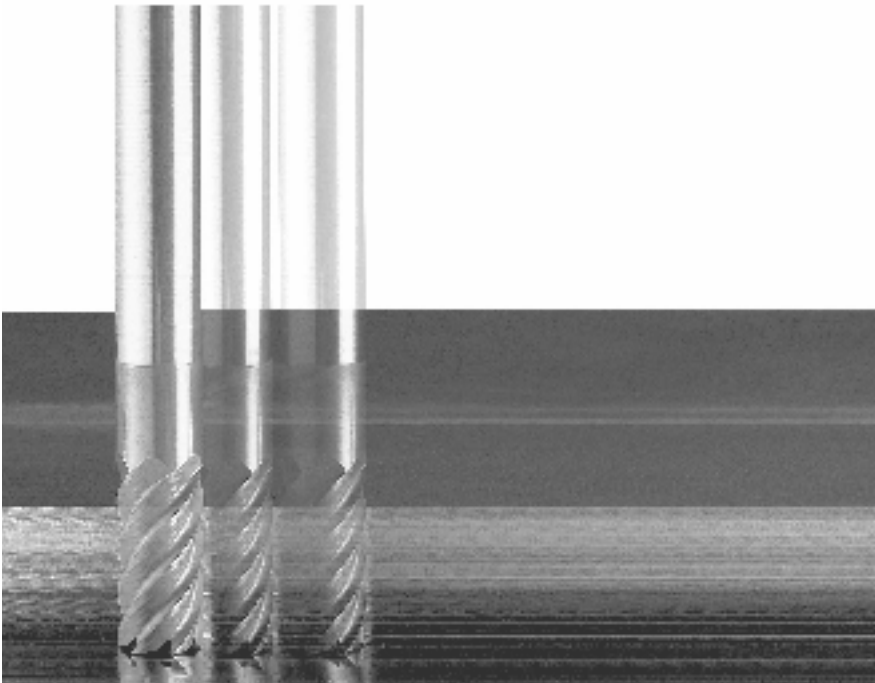

Extremely thin and harder than steel, BALINIT® PVD Coatings significantly reduce cutting friction and tool wear. Even in tough materials such as titanium, Inconel, and Incoal, cutting tools coated with BALINIT® PVD Coatings increase cutting tool performance, part quality, and tool life.

Cerlikon Balzers is the global leader in PVD coating technology. No matter your location, you'll benefit from localized service and quick turnaround. Visit our website or call us for more information.

Cerlikon Balzers USA, Inc.  
+1 800 792 3226  
info.balzers.us@cerlikon.com

www.cerlikon.com/balzers/us

cerlikon  
balzers

insert run at 1,000 rpm and 0.002 ipr cuts three 0.50"-wide snap ring grooves. The tool is programmed to exit the cut at 0.004 ipr. "When you go down to the bottom of a groove," Cox said, "you don't want to dwell because you will pick up some chatter. Titanium has a tendency to do that. When we do grooves in titanium, we pull off at twice the feed rate."

The part is then flipped in the collet and faced with the VNMG insert to bring the length to 7.85". To accommodate a tailstock for support in later operations, the end

shoulder and tapering to a 0.43" diameter at the part's threaded end.

The part is then moved to a Hurco VM1 vertical machining center and clamped in a fixture that holds it vertically with the 0.700"-dia. axial hole facing the spindle. A Hanita 1/4"-dia., TiAlN-coated endmill with a 0.04" corner radius mills a 0.175"-deep x 0.275"-

wide slot across the hole's mouth. "We take one pass across the center of the part and then side cut a roughing pass and a finishing pass on each side," Cox said.

For the final set of operations, the part is positioned horizontally in a V-block fixture, clamped against the shoulder on the 1.18" diameter and supported

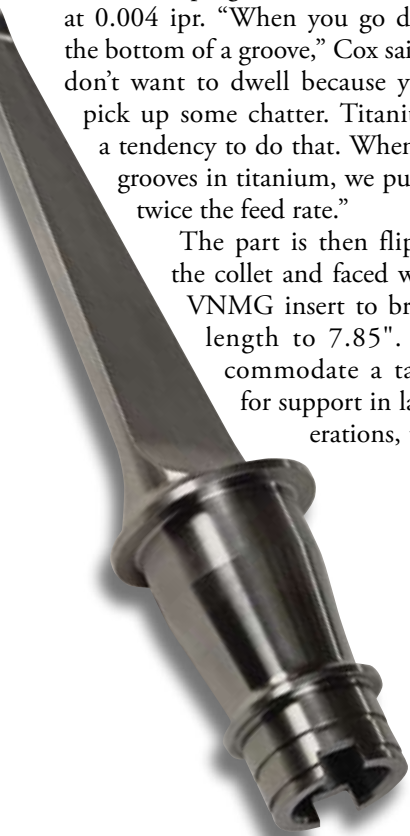

B. Kennedy

Rayco Machine & Engineering Group Inc. produces this 8"-long, 1"-dia. titanium suspension component for an Indy Racing League racecar.

of the part is drilled with a No. 1 center drill. After the tailstock is brought in, the VNMG insert turns a 0.25" diameter for a distance of 0.310" and then steps up to a diameter of 0.54" for a distance of 0.312" that will serve as bearing surface. The tool runs at the same roughing and finishing speeds and feeds used earlier. On the 0.25"-dia., a Kennametal KC730 Top Notch J-thread threading insert run at 1,000 rpm machines a 1/4-28 thread.

Next, Rayco switches to a dead-length collet to maximize rigidity and grips the part on the 1.18" diameter behind the shoulder. The tailstock again supports the part's threaded end. Then the VNMG insert, at the previously applied roughing and finishing speeds and feeds, turns a 4.55"-long profile, beginning with a 1 1/2" diameter at the

## Custom Deephole Tooling

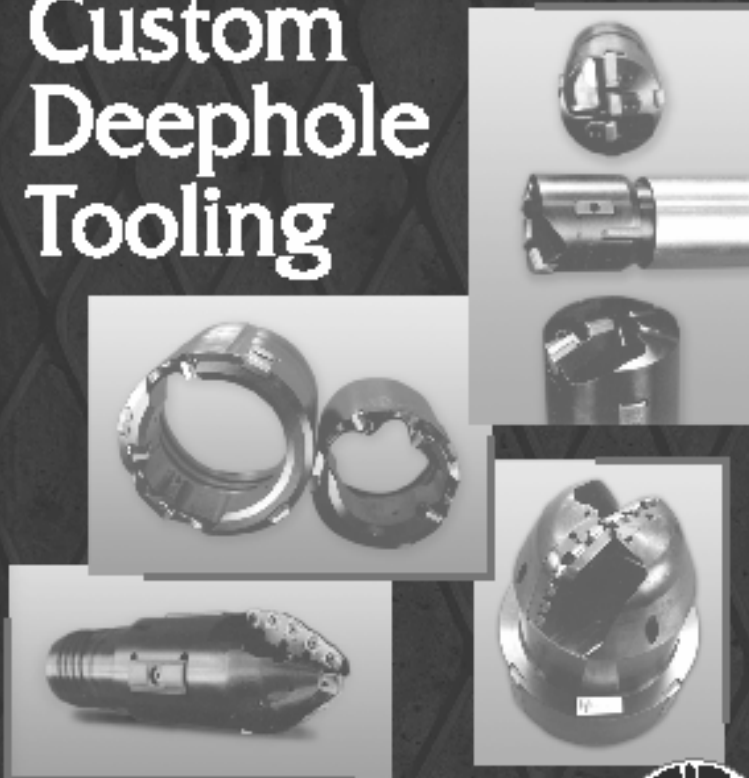

Our "Jetstream" tools for deephole reaming, trepanning and forming, use disposable positive inserts, come in any shank size and feature internal or external chip expelling.

Precision computer-driven design and production technology assures stringent quality, durability and on-time delivery. So make life easy on yourself and "Handle it with Hamiltons" ... we'll both be glad you did!



**QUALITY · RELIABILITY · ECONOMY**

1.800.724.1799 - 1.814.724.5898  
[www.hamiltontoolcompany.com](http://www.hamiltontoolcompany.com)

on the bearing diameter on the other end. The fixture features a face plate with a machined square block that fits the cross-slot, guaranteeing that the relationship between the slot and the flats that are milled next will be consistent.

Rayco applies Hanita ½"-dia., 4-flute, TiAlN-coated endmills for roughing and finishing the flats. The side

of the endmill machines the part's full width on each of four passes, removing material gradually. The four roughing passes take place at 1,800 rpm and 25 ipm. Finishing also occurs at 1,800 rpm, but at a 20-ipm feed.

Cox said: "I take 0.0005" off the face with a finishing pass and then go back and do a spring pass. The spring pass

goes to the exact same position as the finish pass. I just rerun the tool over the part to allow for any spring in the material. Sometimes you can't even see any shavings coming off."

To obtain a fine surface finish, Rayco uses separate endmills for roughing and finishing. Cox said a fine finish requires a cutter that remains sharp at the end of the finishing passes, adding that a finishing cutter lasts six parts before it needs to be changed or have its flutes reground.

As the part is milled thinner, it becomes more flexible. The final thickness is 0.160". To maintain rigidity, the fixture is drilled with two holes to accept dowel pins, which support the part when the second side is being milled. After the first side is rough and finish milled, the endmill retracts to the home position, the part is removed from the fixture, and the pins are set into the holes. The part is replaced in the fixture with the milled side resting on the pins, which prevents the part from flexing. The second side is rough and finish milled, and recognizing the increased flexibility of the now-thinner part, Rayco performs two spring passes.

After hand deburring, the parts are ready to ship. Rayco makes 4 to 6 parts for each race team to use as replacements in the event of a crash or other damage. It also makes 4140 steel parts for Dallara as well as titanium ones. "You get more flex from titanium than from steel," Cox said.

Cox is a self-described "shop rat" who's worked at Rayco, founded by his father, since 1979. From three employees, the shop has grown to employ 22. It operates 13 CNC machines. CTE

## Ultra-Mill™

Designed specifically  
for machining aluminum.



The patented Ultra-Mill milling cutter from SP3 has been designed to accommodate a wide range of coarse, medium, and fine slot cutting applications by using a common body style and allowing the user to select different applications simply by changing cartridge styles.

Our patented Y-style pocket design also permits up to twice as many cartridges to be incorporated in a given body size. This enables faster running speeds and feeds for any size cutter body, or alternatively, much longer tool life at the same feeds and speeds, either way the Ultra-Mill is a means to reduce cost throughout your operations.

Contact SP3 today and allow us to optimize your machining application, you won't be disappointed!

**SP3**  
DIAMOND  
CUTTING TOOLS

SP3 Cutting Tools, Inc. | (800) 547-4156 | [info@sp3.com](mailto:info@sp3.com) | [www.sp3.com](http://www.sp3.com) | Danbury, CT

For more information about Rayco Machine & Engineering Group Inc., call (317) 291-7848 or visit [www.raycomachine.com](http://www.raycomachine.com).

### contact us

If you have manufactured a part that would make a good Part Time candidate, contact Contributing Editor Bill Kennedy at (724) 537-6182 or [billk@jwr.com](mailto:billk@jwr.com).



# Push-off in OD grinding

**Dear Doc:** I grind the ODs of cylindrical shafts in a single plunge operation. The shafts are squared at the ends. I have out-of-roundness problems and find the high points on my wheel are always where the square ends meet the OD. Why?

**The Doc Replies:** In every grinding operation the workpiece pushes against the wheelhead. This causes the wheel to displace, or push off, a certain amount from its normal position. Push-off increases with higher material-removal rates, lower spindle or tool stiffness and, in particular, with a greater degree of wheel dulling.

In your case, the WOC increases at the four corners of the square. This increases push-off.

Because you're plunging, the wheel width is fixed, so you'll have to live with a certain degree of variation in the amount of push-off. But remember, push-off increases drastically as a wheel dulls. A sharp wheel might push off 0.0001". A dull wheel pushes off 10 times that amount.

I've reduced push-off by dressing the wheel so it's very sharp. This reduces the normal force and consequently the variation in push-off.

The best way to sharpen a wheel is to dress with a faster diamond traverse. And, in spite of what some diamond manufacturers and wheel salesmen say, there's no shame in taking a fast return dressing pass without in-feed to clean up missed grits.

A few months ago, I was working on an old Cincinnati OD grinder where the operator was getting 0.001" runout, right at the limit of his tolerance. We opened the hydraulic valve all the way and raced the diamond dresser across the wheel and then did a clean-up pass. By doing this, we were able to reduce runout to about 0.0003". The tradeoff was a slightly rougher surface finish, which was OK. If not, we would have had to increase spark-out or switch to a finer-grit wheel. But a sharp-dressed, finer-grit wheel gives less push-off than a dull-dressed, coarser-grit wheel.

**Dear Doc:** I'm thinking of switching from neat oil to a water-based coolant. What kind of performance

changes can I expect?

**The Doc Replies:** Water-based coolant is better for the birds, the trees and an operator's skin, easier to dispose of, doesn't ignite and is more pleasant to smell. So, I'd like to say you'll get the same results with a water-based coolant as oil. But my experience doesn't bear that out, nor does everything I've heard from others in the industry. In almost all cases, you'll get better results with oil.

The cliché is that water cools better and oil lubricates better, so they balance each other out and are equally effective. But that argument just doesn't fly.

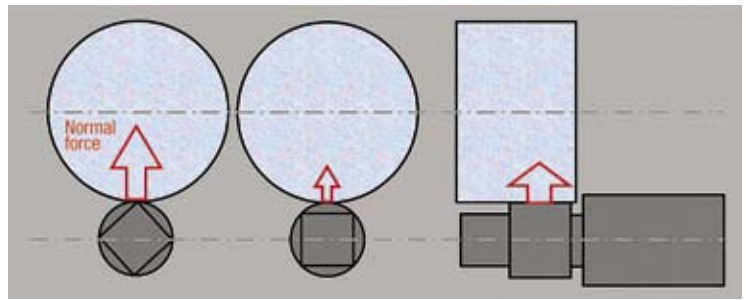

J. Badger

Push-off increases in OD grinding of cylindrical shafts with squared ends because the WOC increases at the square's four corners.

Water cools somewhat better, but oil lubricates a lot better. And in the vast majority of grinding operations, lubrication is far more important than cooling. So, water removes heat more quickly, but oil generates less heat to begin with, and the net heat entering the workpiece will be lower with oil.

Oil also retards strange chemical reactions between the grit and the workpiece, reducing loading, and it provides less wheel wear and a finer surface finish. What's more, oil boils around 500° C, whereas water-based coolant boils at just over 100° C, and steam has poor cooling and lubricating properties. I wish it weren't true, but oil simply outperforms water-based coolant in the vast majority of applications. **CTE**

**About the Author:** Dr. Jeffery Badger is an independent grinding consultant. His Web site is [www.TheGrindingDoc.com](http://www.TheGrindingDoc.com). E-mail grinding questions to him at [alanr@jwr.com](mailto:alanr@jwr.com).